

Issue:
30.10.2015
TD 64521200

KNX RF USB data interface (USB stick)

Order No. 5120 00



Table of Contents

1	Product definition	3
1.1	Product catalogue	3
1.2	Function	3
2	Installation, electrical connection and operation	4
2.1	Safety instructions	4
2.2	Device components	5
2.3	Commissioning	6
3	Technical data	8
4	Software description	9
4.1	Software specification	9
4.2	Scope of functions	10
4.3	Notes on software	11
5	Appendix	12
5.1	Application basics	12
5.1.1	The KNX RF system	12
5.1.2	Basic physical principles	16
5.1.3	Building structure and RF topology	23
6	Index	36

1 Product definition

1.1 Product catalogue

Product name: KNX RF USB data interface (USB stick)

Use: Interface

Design: USB (USB stick)

Order No. 5120 00

1.2 Function

The device serves as an interface to KNX installations via radio using the KNX RF standard KNX RF1.R (RF = radio frequency). This allows communication between KNX devices and PC tools.

The communication between PC and KNX system is established via radio. For this purpose appropriate KNX RF devices or KNX RF/TP media couplers are required in the KNX system. The connection to the computer (USB 2.0 type A) takes place via a USB port. With the help of the KNX RF USB data interface, the addressing, programming and diagnostics of the KNX devices can be performed by the commissioning software from version ETS5 or higher.

The device electronics are supplied fully via the USB interface of the connected PC. For this reason the KNX RF USB data interface is not ready for operation if the USB stick is not inserted or the PC is not switched on.

The physical address of the interface is solely programmed (ETS) locally via the connected PC. Thus, the KNX RF USB data interface has neither a programming button nor a programming LED.

Only standard Windows HID drivers that are installed or activated automatically when attaching the KNX RF USB data interface to the PC are required for the device to function. The device can first be accessed by the ETS after successful installation.

2 Installation, electrical connection and operation

2.1 Safety instructions

Electrical equipment may only be installed and fitted by electrically skilled persons. The applicable accident prevention regulations must be observed.

Failure to observe the instructions may cause damage to the device and result in fire and other hazards.

The radio communication takes place via a non-exclusively available transmission path, and is therefore not suitable for safety-related applications, such as emergency stop and emergency call.

2.2 Device components

The structure of the KNX RF USB data interface corresponds to a standard USB stick (USB 2.0 Standard-A). The KNX RF USB data interface is compatible with a USB port (recording type USB 2.0 Standard-A) accordingly. There are no controls or indicators on the device.

The KNX RF USB data interface has a compact plastic housing and an interlocking cap for protecting the USB plug. The housing of the KNX RF USB data interface has been designed so that the protection cap can be attached to the back end of the stick provided while the KNX RF USB data interface is connected to a PC.



Figure 1: Device components

(1) USB type A plug

- i** To protect the KNX RF USB data interface, it is necessary to ensure that the protection cap is always used when the KNX RF USB data interface is not in operation.

2.3 Commissioning

Establishing a connection between the KNX RF USB data interface and a PC

The KNX RF USB data interface must be connected to a PC before commissioning the device by the ETS.

Operable PC with USB port (recording type USB 2.0 Standard-A).

- Remove the protection cap from KNX RF USB data interface. (Recommendation: Attach the cap to the back end of the KNX RF USB data interface)
- Insert the KNX RF USB data interface into a free USB port of the switched-on PC.
The operating system installs the required USB driver automatically. After successful installation, the KNX RF USB data interface is ready for operation.

i If the KNX RF USB data interface is inserted into a PC for the first time, it will first be initialised by the operating system. It may take several minutes to search for a suitable driver.

The KNX RF USB data interface establishes the connection between a PC and the KNX installation. The KNX RF USB data interface works in accordance with the KNX standard, which means that the addressing, programming and diagnostics of the KNX devices can take place by the KNX certified software from version ETS5 or higher.

The device only requires HID drivers to function (HID = Human Interface Device). One advantage of this device class is the fact that the required drivers are available in the operating system. When attaching the KNX RF USB data interface to the PC, the drivers are installed or activated automatically (partially user-controlled depending on the operating system). The user might be requested to insert or specify the installation source of the operating system. USB support is possible in current Windows operating systems. The device can first be accessed by the ETS after successful installation or activation of the drivers.

Programming the physical address

The physical address of the KNX RF USB data interface is solely programmed locally by the commissioning software from version ETS5 or higher.

The ETS is installed on the PC.

The KNX RF USB data interface is connected and ready for operation.

- Click on the "Connections" function under the "Bus" tab.
- Select the "Interfaces" subarea.
The "KNX RF USB data interface (GIRA Giersiepen)" is displayed under "Interfaces found".
- Click on the interface so that the entry in the list is selected.
- i** Press the "Test" button to check whether the KNX RF USB data interface is connected and ready for operation. If the test fails, check whether the KNX RF USB data interface is inserted correctly and was detected by the PC. Furthermore, the driver installation must be completed correctly.
- Press the "Select" button to define the selected interface as the currently used interface.
The "KNX RF USB data interface (GIRA Giersiepen)" is displayed under "Current interface".

After the required KNX RF USB data interface has been activated, two addresses are to be assigned to this interface.

- Click on the KNX RF USB data interface so that the entry in the "Current interface" list is selected.

- Enter the physical address.
- ❗ Care must be taken to ensure that the physical address entered here is not used by another device in the system and corresponds to the topology of the KNX system.
- Press the "Address free?" button to make sure that the entered physical address is not used by another KNX device.

By leaving the field, the physical address is programmed to the KNX RF USB data interface. The newly programmed physical address is displayed under "Current interface".

Assignment of the domain address

For an RF device to be programmed by the ETS, the domain address of the RF line must match the domain address of the RF communication interface (e.g. KNX USB RF USB data interface)! Otherwise, the ETS will be unable to reach the RF devices of the affected line. The domain address of the KNX RF USB data interface used by the ETS is configured in the general connection settings of the ETS. In an ETS project, the domain address of an RF line is configured in the line properties (separate for each RF line).

A physical address was assigned to the KNX RF USB data interface.

- Click on the "Connections" function under the "Bus" tab.
- Select the "Interfaces" subarea.
The "KNX RF USB data interface (GIRA Giersiepen)" is displayed under "Current interface".

Besides the physical address already programmed, it is necessary to assign the domain address.

- Enter the domain address in the field provided.
- ❗ A domain address is 6 bytes long and is entered in the ETS in hexadecimals or generated automatically. After the first 2 bytes, the input notation requires a colon (when read from the left). For example, a domain address could look like this: "0011:22334455" or "00FA:4F5B3122".
- ❗ Only devices with the same domain address can communicate with each other. Thus, a KNX RF USB data interface must always have the same domain address as a KNX RF device to be addressed or programmed.

By leaving the field, the domain address is written in the KNX RF USB data interface.

Once a physical address and a domain address have been programmed to the KNX RF USB data interface, the interface can be used by the commissioning software from version ETS5 or higher for addressing, programming and diagnostics.

3 Technical data

General

Rated voltage	DC 5 V
USB version	2.0
USB connection	Type A
Ambient temperature	-10 ... +70 °C
Degree of protection	IP 20
Relative humidity	max. 80 % (No moisture condensation)

KNX

KNX medium	RF1.R
Radio frequency	868.3 MHz
Transmitting power	max. 20 mW
Transmitting range in free field	typ. 100 m

4 Software description

4.1 Software specification

ETS search paths: - Communication / Radio / KNX RF USB data interface (USB stick)
 - Communication / USB / KNX RF USB data interface (USB stick)
 - Radio / Data interfaces / KNX RF USB data interface (USB stick)

Configuration: S-mode standard

No.	Short description	Name	Version	from mask version
1	No application program is required for this device! The physical address and domain address are assigned solely in the general interface settings of the commissioning software from version ETS5 or higher.	---	---	---

4.2 Scope of functions

- Connecting a PC to the KNX.
- Addressing, programming and diagnostics of KNX-RF devices by the KNX certified commissioning tool from version ETS5 or higher.
- The device electronics are supplied fully via the USB interface of the PC.
- The firmware of the device can be updated. Thus, the device can be adapted to future standards.
- Only standard Windows HID drivers that are installed or activated automatically when attaching the device to the PC are required for the device to function.

4.3 Notes on software

ETS project design and commissioning

For project design and commissioning of the device, the commissioning software from version ETS5 or higher is required.

The physical address and domain address are assigned solely in the general interface settings of the ETS.

This device has no parameters and objects. Thus, it is not necessary to program an application program. The product database available to the product can be imported to the ETS. No settings are possible, however. The device can be added to an ETS project with the aid of the product database. This means that the KNX installation e.g. for documentation of the system, can be fully mapped in the ETS.

Physical address and domain address

Different RF lines can be operated in a KNX system. The RF lines are separated logically (radio communication islands) and are each separately connected to the wired KNX media (e.g. TP) using media couplers. In accordance with the topology defined in the ETS project, devices assigned to the RF lines receive physical addresses. These physical addresses must suit the line address of the corresponding media coupler, as a media coupler functions like an area line coupler (depending on the configuration) and can filter physical addresses. In addition, a unique domain address is assigned to each RF line in the ETS. This is required so that in an open communication medium, such as KNX-RF, devices can be grouped, topologically structured and commissioned in the same way. Only devices with the same domain address can communicate with each other. Thus, a KNX RF data interface must always have the same domain address as a KNX RF device in order to be addressed or programmed.

- i** A domain address is 6 bytes long and is entered in the ETS in hexadecimals or generated automatically. After the first 2 bytes, the input notation requires a colon (when read from the left). For example, a domain address could look like this: "0011:22334455" or "00FA:4F5B3122".
- i** RF lines of a joint KNX installation or of directly adjacent KNX installations in radio range may never have an identical domain address! The ETS offers a function for random assignment of domain addresses for RF lines, in order to avoid this improper situation. When the random function is used, the probability of multiple assignment of an identical address is more or less non-existent. Domain addresses automatically generated by the ETS are characterised by the hexadecimal characters "00FA..." (e.g. "00FA:4D6C3F58").

For an RF device to be programmed by the ETS, the domain address of the RF line must match the domain address of the RF communication interface (e.g. KNX USB RF data interface or media coupler). Otherwise, the ETS will be unable to reach the RF devices of the affected line. The domain address of the RF data interface used by the ETS is configured in the general connection settings of the ETS. In an ETS project, the domain address of an RF line or a media coupler is configured in the line properties (separate for each RF line).

- i** The domain address is programmed automatically into the RF device by the ETS when the physical address is assigned.

5 Appendix

5.1 Application basics

5.1.1 The KNX RF system

Introduction

The Gira KNX RF system (RF = Radio Frequency) is based on a manufacturer-independent KNX radio standard (868 MHz), with which existing KNX systems can be refitted or new installations can be expanded simply using RF components. Mobile hand-held transmitters allow easy operation of the intelligent KNX building functions via "remote control". RF pushbutton sensors can be mounted anywhere in which a control panel is required, no matter whether that is on stone, concrete, wood or glass walls or on the surfaces of furniture. KNX RF devices can be connected to wired KNX installations using media couplers. Additionally or alternatively, suitable RF actuators can be activated and evaluated directly by RF transmitters. Whilst TP or RF actuators are located where cables are present, cables are not relevant during the mounting of KNX RF pushbutton sensors and hand-held transmitters, as these Gira RF transmitters are battery-operated.

KNX RF components possess a transmit and receive module and are thus bidirectional. This means that it is possible, for example, to implement status displays on the RF control panels, in addition to the operating function, or to allow status feedback for actuators. In addition, bidirectional communication makes ETS commissioning possible.

Gira KNX RF hand-held transmitters and KNX RF pushbutton sensors are battery-operated. To prolong the life of the battery, the devices possess an energy-saving mode. After the last operation or after an ETS programming operation, the devices switch automatically to the energy-saving mode (semi-bidirectional operation) after a settable time. The devices temporarily have no function. If an RF device is in energy-saving mode, this mode must be actively terminated before a programming operation by the ETS is possible. This can usually be done by pressing a button or the programming button. The same applies to the unloading of the application program or reading out of the device information by the ETS.

- i** If energy-saving mode is active, the receiver of a semi-bidirectional RF device is switched off. In consequence, the device cannot receive any telegrams, meaning that status changes of group addresses cannot be tracked. In the case of hand-held transmitters or pushbutton sensors which are configured to the button function "Switching - TOGGLE", it can thus be necessary to press the button up to twice for the switching command (ON -> OFF / OFF -> ON) to be switched correctly.
- i** The ETS requires the user to press the programming button if no direct access to the devices is possible due to an active energy-saving mode.

Gira KNX RF devices correspond to the KNX standard "KNX RF1.R S-Mode". Devices of other manufacturers, which meet the same standard, are intercompatible. Frequently, for marketing reasons, different names or product designations are used for the same KNX RF system. The designations named below usually indicate, if necessary also in combinations, products of the same KNX standard.

- KNX RF1.R S-Mode
- KNX RF Ready S-Mode
- KNX RF 868 MHz
- KNX RF+

Approval and frequency use

KNX RF (KNX RF1.R) uses a frequency from the Europe-wide SRD band (SRD = Short Range Device). Low-power radio applications are used in this approval-free frequency range. Besides KNX RF, these include, for example, radio remote controllers, wireless microphones and headphones or other simple data transmission systems. KNX RF devices are generally

approved and can thus be used in all the states recognising the standards and directives of the European Union. In general, these include the EU and EFTA states.

The frequency band at 868 MHz as used by the KNX RF has good characteristics in buildings with respect to the signal distribution, since the attenuation due to walls, concrete reinforcements and metal parts keeps within reasonable limits.

Frequency	Transmitting power	Application (example)
26.9 ... 27.2 MHz	≤ 10 mW	PC devices, babyphones, model radio
40.6 ... 40.7 MHz	≤ 10 mW	Model radio
433.05 ... 434.79 MHz	≤ 10 mW	Motor vehicle remote controls, headphones, weather stations
446.0 ... 446.2 MHz	≤ 500 mW	PMR radio equipment
868.0 ... 868.6 MHz	0.5 ... 25 mW	KNX RF

Overview of standard SRD frequency bands

Besides the SRD frequency bands, there are additional frequency ranges provided for other radio services from different areas of application (e.g. analogue and digital audio and video transmission systems, Wi-Fi, Bluetooth). The division into frequency ranges according to the approved application is required for the range of different radio services to coexist and not interfere with one another.

The frequency range used by KNX RF is not exclusively available to the KNX radio service. In this frequency range too, there may be radio systems existing in parallel in a building, which have an influence on signal transmission. Through the joint use of a frequency range, it is possible that interference between the various radio services can occur, meaning the loss of transmitted information.

- i** Besides available third-party radio services, other devices emitting electromagnetic waves (e.g. electrical machines, electronic ballasts and lighting, microwave ovens) may be potential sources of interference for KNX RF systems. This is then particularly problematic when the named devices are located in direct proximity to KNX RF devices. For this reason, sources of interference in immediate proximity to KNX RF devices during the planning of the electrical installation are to be avoided as far as possible.

Frequency	Transmitting power	Application (example)
868.0 ... 868.6 MHz	≤ 25 mW	Including radio alarm systems, garage door openers, eNet
2.40 ... 2.48 GHz	≤ 100 mW	WLAN, Bluetooth
5.725 ... 6.875 GHz	≤ 1,000 mW	WLAN

Overview of standard radio services in the same and neighbouring frequency ranges to KNX RF (also not SRD)

With KNX RF1.R, the mean frequency is specified as 868.3 MHz. Transmission power in the range 0.5...25 mW is possible. The system makes a communication channel available for all devices. The transmission time of each device (Duty-Cycle) is 1 % (maximum transmission time 0.6 seconds in one minute). This avoids continuous transmissions, meaning that the transmission channel is not permanently blocked.

Control of media access

When it wishes to transmit a KNX telegram, each KNX RF transmitter checks whether the radio channel is already occupied by another RF transmitter (LBT: Listen Before Talk). If this is the case, the RF transmitter waits with the required radio transmission. It transmits its own telegram as soon as the radio channel is free again.

In addition, each RF transmitter waits for a short random interval on each transmission request, before the radio telegram is actually transmitted. This random time is of different length for each transmission operation. This suppresses to a great extent radio collisions between devices which actually wish to transmit simultaneously (e.g. media couplers, which have received a group telegram to be forwarded via the TP side), in combination with LBT.

The described transmission method for controlling media access generally prevents radio collisions in a KNX RF environment, but cannot exclude them completely. For example, it may occur that, in the case of a transmission between an RF transmitter (A) and an RF receiver (B), there is an additional RF transmitter (C), which is located within the range of the RF receiver, but cannot reach the other RF transmitter due to the spatial distance (Figure 2). In such a case, the two RF transmitters are unable to detect when the other transmits radio signals (Hidden Station Problem). In consequence, radio collisions can occur on the receiver located in the range of the two RF transmitters.

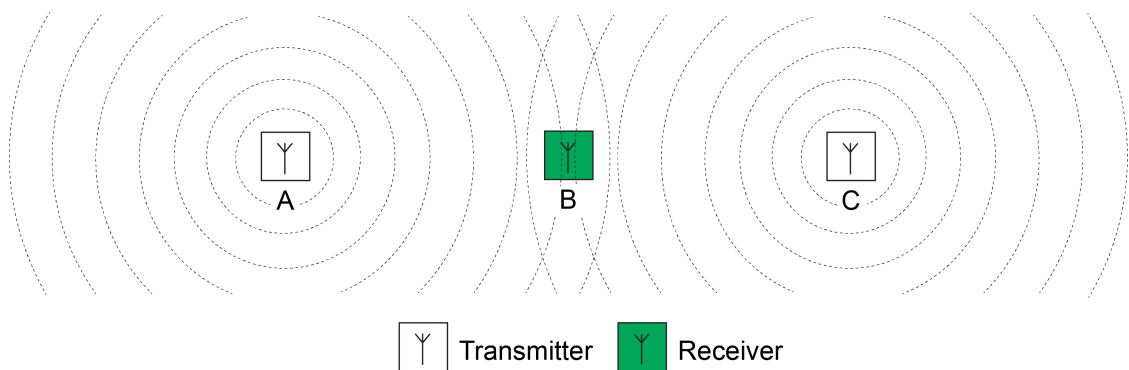

Figure 2: Radio collisions on the receiver due to the transmitter being too far away

The described effect is system-dependent and can be a particular problem when there are two or more media couplers in a KNX system. If the media couplers are out of the other's range, then they cannot detect whether another media coupler is already transmitting a group telegram. However, the KNX subscribers in the various RF lines can be located in such a way that they are in the overlap areas of the RF domains of the couplers. In consequence, the subscribers receive the colliding telegrams of multiple media couplers (Figure 13).

This circumstance must already be taken into account during the planning of a KNX RF system.

- If possible, position media couplers in such a way that they are within direct reception range of each other.
- Structurally decouple RF domains in such a way that their subscribers are only positioned in their own RF environment.
- Use repeaters instead of media couplers, if this is wise from a structural and topological point of view. Repeaters should be located within the range of the media coupler and also within the ranges of other repeaters.

i If complete separation of RF domains or the integration of media couplers into their radio ranges cannot be guaranteed structurally, then it may be better to create only one radio domain instead of multiple media couplers and to work with repeaters.

- i** Expert knowledge:
With KNX TP (TP = Twisted Pair), the bus access of a subscriber is controlled by the CSMA/CA method (Carrier Sense Multiple Access/Collision Avoidance). This bus access method avoids telegram collisions. In addition, received telegrams are confirmed by each addressed TP bus subscriber (telegram confirmation through LinkLayer-Confirm: Ack, Busy, Nack). This allows transmitters of KNX messages to detect whether potential receivers have understood the message or whether telegram repetitions are necessary due to transmission or processing errors.
These security mechanisms are not available within a KNX RF1.R radio domain, due to the specifications. If there are transmission errors, media couplers, which forward RF telegrams to the TP side, can repeat telegrams up to three times. Telegrams forwarded on the RF side are only transmitted once.
Media couplers can perform a telegram confirmation on the TP line for received telegrams. As described, this is not possible for telegrams received on the RF side.

5.1.2 Basic physical principles

Electromagnetic wave

Radio waves are waves of coupled electrical and magnetic fields (Figure 3). Electromagnetic waves are emitted by antennas into the surrounding area as free progressive waves. They do not require a special medium for radiation. In a vacuum, radio waves radiate at the speed of light. The radiation is always slower in other media. Like light, electromagnetic waves are subject to deflection, refraction, reflection, polarisation and interference.

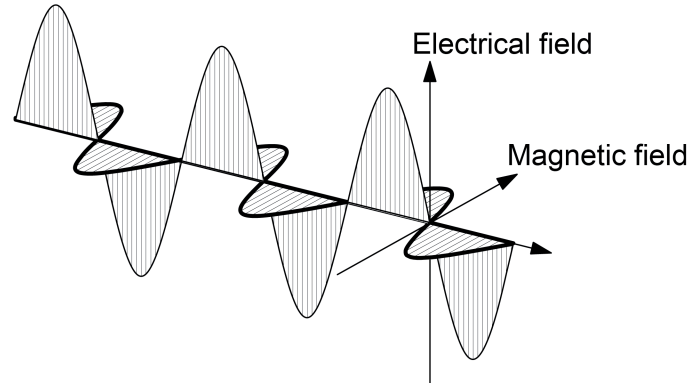

Figure 3: Model of an electromagnetic wave in an open space

Electromagnetic waves radiate out in a straight line in every direction. If multiple electromagnetic waves meet, then they will be superimposed. With KNX RF, the radio signals come from almost every direction (through the positioning of the transmitters and due to reflections). If KNX RF radio waves are superimposed, then noise is created (signal with an unspecific frequency spectrum) in the communication channel, which can no longer be understood by any KNX RF receiver. This can cause transmitted information to be lost. Therefore, when planning a KNX RF environment, various specifications must be taken into account. The chapter "Building structure and RF topology" in this documentation provides more detailed information on this.

Information transmission with radio signals

An electromagnetic wave of a constant amplitude and frequency does not yet carry any information. To make this possible, the transmitter must change the amplitude or the frequency of the wave continuously according to an agreed method and the carrier signal must modulate the information in this manner. With KNX RF, the modulation type "Frequency key shifting" (FSK = Frequency Shift Keying) is used (Figure 4). Frequency key shifting is a variant of frequency modulation (FM) and suitable for the transmission of digital information. Two time-coded signals of a different frequency are transmitted, in order to inform the receiver of the logical states "0" and "1". Frequency key shifting is impervious to interference. Even major transmission losses in signal amplitude do not have a negative effect on the demodulation of the transmitted information.

For KNX RF, the data rate is 16.384 kBit/s. Manchester encoding is used to apply the "0" and "1" information to the radio signal. This allows very easy synchronisation of the transmitter and receiver.

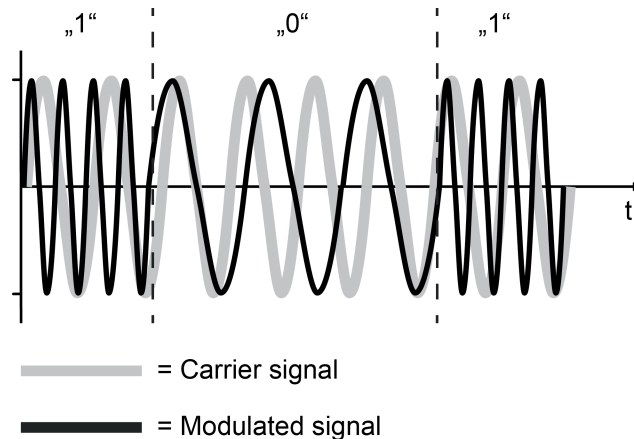

Figure 4: Frequency key shifting as a modulation method (FSK = Frequency Shift Keying)

Radiation and attenuation of radio signals in buildings

Radio waves with a frequency used for KNX RF can penetrate ceilings or walls in a building. Depending on the mass (thickness) and conductivity (metallic component, humidity), this is connected with a greater or lesser energy loss. This loss of transmission energy is also called attenuation (ratio of transmitted and received radio radiation power).

Radio signals are attenuated by various influences on their journey between the transmitter and receiver. The precondition for comprehension between the transmitter and receiver is, of course, that the radio signals of the transmitter still have sufficient energy on reaching the receiver for the receiver to be able to evaluate the signals.

Almost ideal radiation conditions for electromagnetic radio signals exist in the free-field. The term "Free-field" refers to a free area, in which radio waves can radiate out more or less unhindered and interference effects from structures or obstacles have no influence.

If walls and ceilings must be penetrated on the transmission path, then the attenuation - and thus the radio range - is primarily dependent upon the number, type and consistency of the construction materials to be penetrated and on the effective wall and ceiling thicknesses. Part of the incidental radio radiation is reflected on the limit areas and a further part is absorbed. Moist materials, as is found in new buildings or recently renovated rooms (newly-papered or plastered) attenuate electromagnetic radio waves to a greater extent.

Material (dry)	Material thickness	Transmission
Wood, plaster, plasterboard *, glass **	< 30 cm	90...100 %
Brick, chipboard plates	< 30 cm	65...95 %
Reinforced concrete	< 30 cm	10...70 %
Metal grid	< 1 mm	0...10 %
Metal, aluminium cladding	< 1 mm	0 %

*: no metallic stand

** : without metallisation or wire inlay, no leaded glass

Take the attenuation factors of a building into account when selecting the mounting locations of KNX RF devices (hand-held transmitters, pushbutton sensors, media couplers). Take into account too that each KNX RF device is both a transmitter and a receiver on account of the bidirectionality (e.g. hand-held transmitters with or without LED status display and media couplers are transmitters and receivers in the same way).









-  Position of transmitters (e.g. hand-held transmitter, pushbutton sensor)
-  Position of possible receivers (e.g. media coupler)
-  In reception field
-  Not located favourably in reception field
-  Not in reception field
-  Attenuated signal path

Figure 5: Attenuation of the radio signal in buildings through walls and ceilings
 Example 1: "Edge position of the transmitter" (simplified depiction)

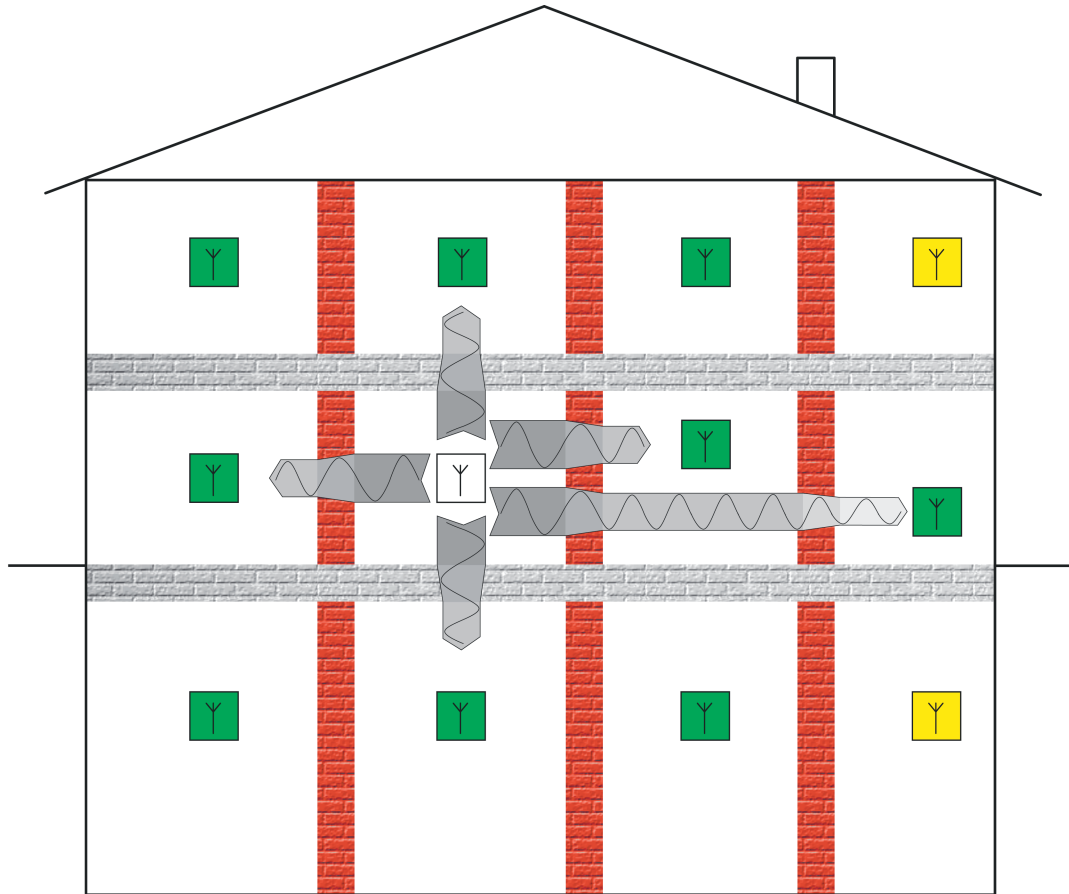

Figure 6: Attenuation of the radio signal in buildings through walls and ceilings
 Example 2: "Central position of the transmitter" (simplified depiction)

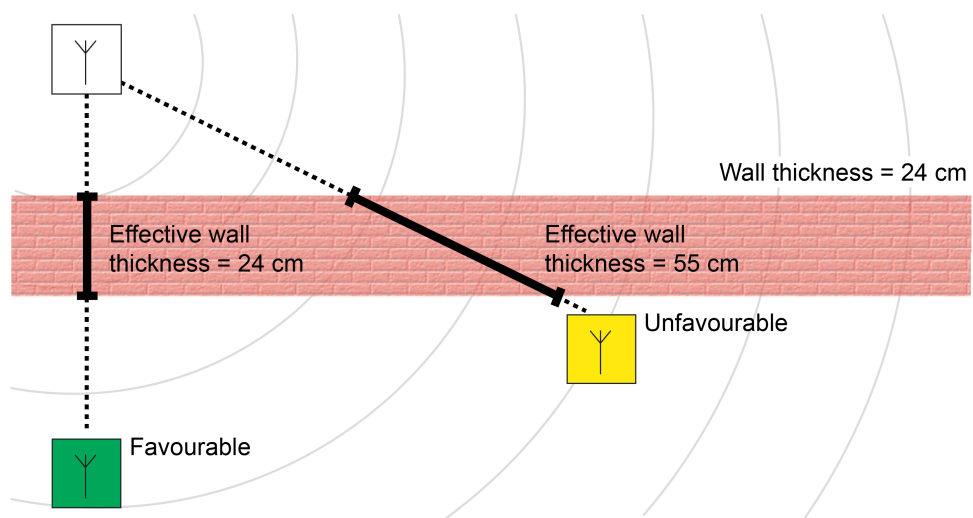

Figure 7: Attenuation through effective wall or ceiling thickness

- i** Care is required when a building is equipped with shielding materials to reduce electromagnetic waves. Flush-mounted boxes with a conductive coating are not usually suitable for radio products. Special shielding plasters and plasterboard protection plates, into which conductive fibres are worked, reduce the permeability of radio waves by up to 95%. The same applies to stands, into which high level of metallic components (e.g. supporting parts, metallised insulation material) are integrated.
- i** Due to the wide range of influences, it is difficult to evaluate radio sections in buildings. Eventually a manufacturer of radio products - also of other systems such as Wi-Fi - cannot make any binding statement on the range of radio transmission in buildings. For this reason, the free-field range is always stated, which refers to an uninterrupted radiation of the radio waves and optimally aligned antennas. Provided that there are no special measures for shielding in buildings, this means that targeted radio transmission should be possible.

Additional attenuation in a building or in a more or less free field (outdoors) is created when the antenna of the transmitter or receiver is mounted at a low ground height. KNX RF radio sensors and actuators should therefore be mounted as far from the ground as possible.

The mounting of a transmitter or receiver in the ground (e.g. in a suitable installation box) should be avoided, particularly outdoors. The radio range would be restricted to such an extent that radio transmission would scarcely be possible.

- i** We recommend installing KNX RF pushbutton sensors at a standard mounting height of 1.05...1.50 m.

Electrically conductive materials cannot be penetrated by electromagnetic waves. Metallic components of buildings, e.g. furniture or steel reinforcement rods in concrete (Figure 8), but also metallic design frames or design parts with metallic coatings thus have a shielding effect. Metallic shieldings can also be used consciously to keep an area free of radio waves.

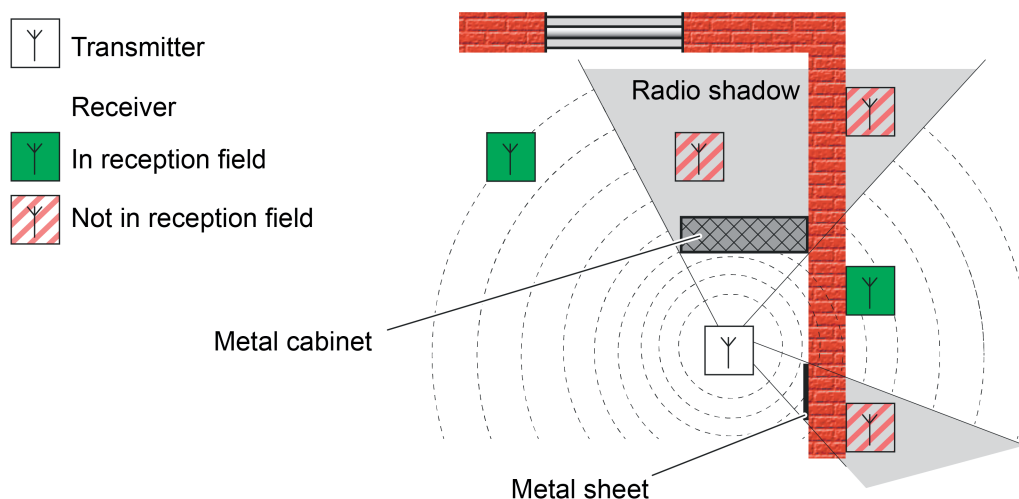

Figure 8: Radio shadow in a building due to metallic parts (idealised)

Radio waves reach the receiver both directly (through the air) and also via diversions (multiple route radiation). Such diversions are created by reflections of the radio waves at boundary layers to other materials, e.g. on the surfaces of walls or ceilings. Radio waves of an identical source are at the receiver with a differing phase location. In many cases, the reflected radio

power is too small to influence the direct path of the radio wave in any significant way. A receiver can then receive the signal of the transmitter without any interference (Figure 9).

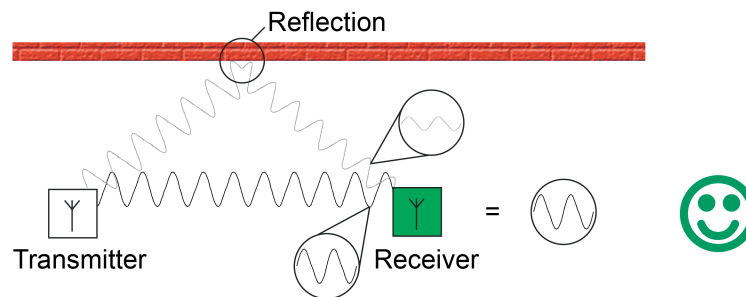

Figure 9: Interference has no effect on the receiver

However, in the worst case, the waves received directly and via reflection are superimposed unfavourably at the target location, creating a signal which receivers can no longer evaluate reliably (Figure 10). Positive and negative superposition of radio waves pointing the same way is also termed interference.

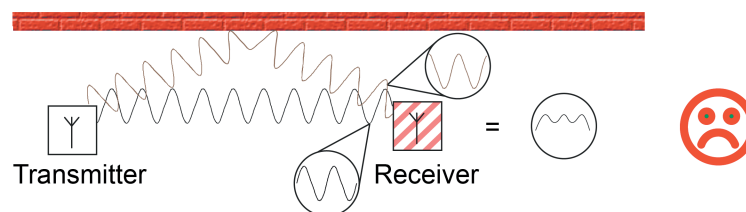

Figure 10: Interference at the receiver prevents reception

Effects from reflections can also be used positively in a building. If possible, RF devices, or their transmission and reception antennas, can be installed horizontally or vertically in the same alignment, as the radio wave also swings in the appropriate direction (polarisation). If antennas are aligned in different ways, then the signal available at the receiver is weakened and thus the maximum radio range is reduced. The weakening of the signal can be of such magnitude that a receiver can no longer receive any output radiated directly from the transmitter. However, in practical terms, reflections may cause a rotation of the polarisation direction, meaning that the reflected signal reaches the receiver in a weakened form and can also be understood there (Figure 11).

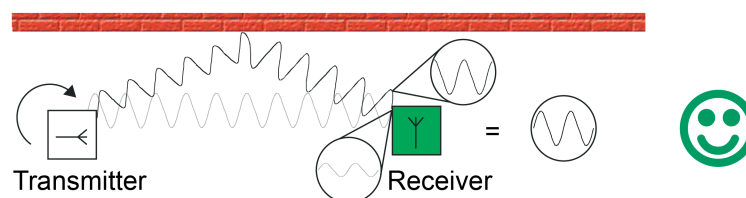

Figure 11: Reflection allows reception through a change of polarisation

In practice, reflection and interference effects can frequently be changed or used beneficially through a slight change in the installation location or the installation environment.

- i** With KNX RF pushbutton sensors, only vertical mounting of the device on walls or objects ensures the alignment of the internal antenna. If all the pushbutton sensors are mounted in the same way, then, in consequence, all their antennas are aligned to one another.

Influence of KNX RF on the human body

For many decades, radio waves have been used intensively for radio and global communication. In particular, the new communication media for wireless telephony (UMTS, LTE, DECT) and network communication (Wi-Fi, Bluetooth) are now being used widely in homes and in industry. However, other electrical devices radiate electromagnetic waves, e.g. microwave ovens.

The use of radio waves is regulated by the state. The assignment of frequency ranges and the specification of limit values ensure that there are no health impacts for people and different radio services do not influence one another. In particular, with regard to the number of electrical applications, wireless computer networks, mobile radio telephones and radio services, it must be established that the radio load of multiple KNX RF installations in parallel remains negligible.

Selecting installation location

If possible, the mounting locations of KNX RF devices must be evaluated during the planning of the electrical installation. Concrete ceilings with metal reinforcements attenuate radio radiation to a greater extent than wooden ceilings. The same applies for mineral plasters or hollow walls on the basis of a metallic stand. Room use should also - if known - be taken into account, because a living room in an existing building offers fewer obstacles to radio radiation than an office with metallic cabinets.

A KNX RF media coupler should ideally be positioned in the centre of an RF installation (domain) to allow low-loss and thus interference-free communication with all the corresponding RF devices. The housing of the media coupler is compact, meaning that it can be installed simply in standard flush-mounted boxes (ideally in cavity walls) or surface-mounted boxes (e.g. in suspended ceiling constructions).

General rules on the mounting of KNX RF devices (transmitters, receivers and media couplers).

- Avoid shadows, reflections, extinguishing of radio signals as far as possible. For this, note the structural conditions (supporting metallic parts, metal reinforcements, metallic wall and ceiling panelling, metal-coated panes of glass / heat protection glazing).
- Do not mount the transmitter and receiver near the earth or ground.
- Align unmoveable devices to each other as identically as possible, so that the internal transmission and reception antennas are polarised identically.
- Position the antenna of the media couplers so that they are as straight (stretched out, unkinked) or as circular as possible in the box.
- Ensure a distance to larger metallic surfaces, e.g. doors, frames, aluminium shutters, ceiling panelling, distribution cabinets, insulating films, ventilation grilles, is maintained.
- Ensure the penetrations of walls and ceilings are as short as possible.
- Do not place KNX RF devices in small metallic distributors or boxes.
- Maintain a distance to electromagnetic interference, e.g. electronic ballasts, motors, Tronic transformers, microwaves.
- Maintain a distance to other radio sources, e.g. wireless telephones, radio headphones, WiFi routers.

- i** During mounting, particularly of media couplers, ensure that the devices are accessible after this.

5.1.3 Building structure and RF topology

Introduction

KNX RF1.R makes a shared communication channel available for all devices. Radio communication, which only has one transmission and reception channel available, can be subject to interference by third-party radio services in the same frequency range or by the same system. Even a second KNX RF line in the same or a neighbouring KNX installation can invoke communication faults in a building. The transmission methods used for KNX RF (LBT: Listen Before Talk) are not always sufficient for ensuring interference-free communication in every case.

A communication fault can occur, for example, when two or more RF environments exist in a building, which do not have an identical radio range and only overlap. For example, in installations with two or more media couplers where the couplers are at some distance from one another. If the media couplers are out of the other's range, then they cannot detect whether another media coupler is already transmitting a group telegram. However, the KNX subscribers in the various RF lines can be located in such a way that they are in the overlap areas of the RF domains of the couplers. In consequence, it is possible that subscribers will receive the colliding telegrams of multiple media couplers. On RF devices, a symptom of such a fault could be that individual telegrams are lost (e.g. control command is not received, there is no status feedback).

- i** Usually, the random delay in transmitting RF telegrams ensures that media couplers on the same TP backbone or main line are unable to simultaneously transmit telegrams to their RF lines during forwarding. Gira media couplers guarantee this function. However, media couplers of other manufacturers can be used, which forward a group telegram received from the TP side to the appropriate RF lines almost simultaneously due to their filter properties, after the couplers have determined that the radio channel is free. In these cases, telegram collisions occur very frequently during the operation of a KNX RF system. For this reason, we recommend you always use Gira media couplers.
- i** Simultaneous transmission of radio telegrams when multiple Gira pushbutton sensors or hand-held actuators are actuated is not possible, as these devices always keep to a varying random time when transmitting. A telegram collision is only excluded by device operation in normal operation, even if a button-press takes place almost simultaneously on multiple control panels.
An absolutely simultaneous reaction to system telegrams (broadcast) or group read telegrams (Read flag set on more than just one subscriber) is not possible on Gira KNX RF devices.

With more than two RF lines in a KNX installation, communication problems can become so great that secure data transmission, and thus a fault-free function of the KNX system, is not possible, either temporarily or continually. For this reason, key conditions are to be checked already during building planning and the planning of the KNX topology and the requirements for the installation and configuration of the KNX RF devices are to be taken into account. This chapter describes in detail all the key aspects to do with the building structure and the ETS integration of KNX RF devices.

Building structure

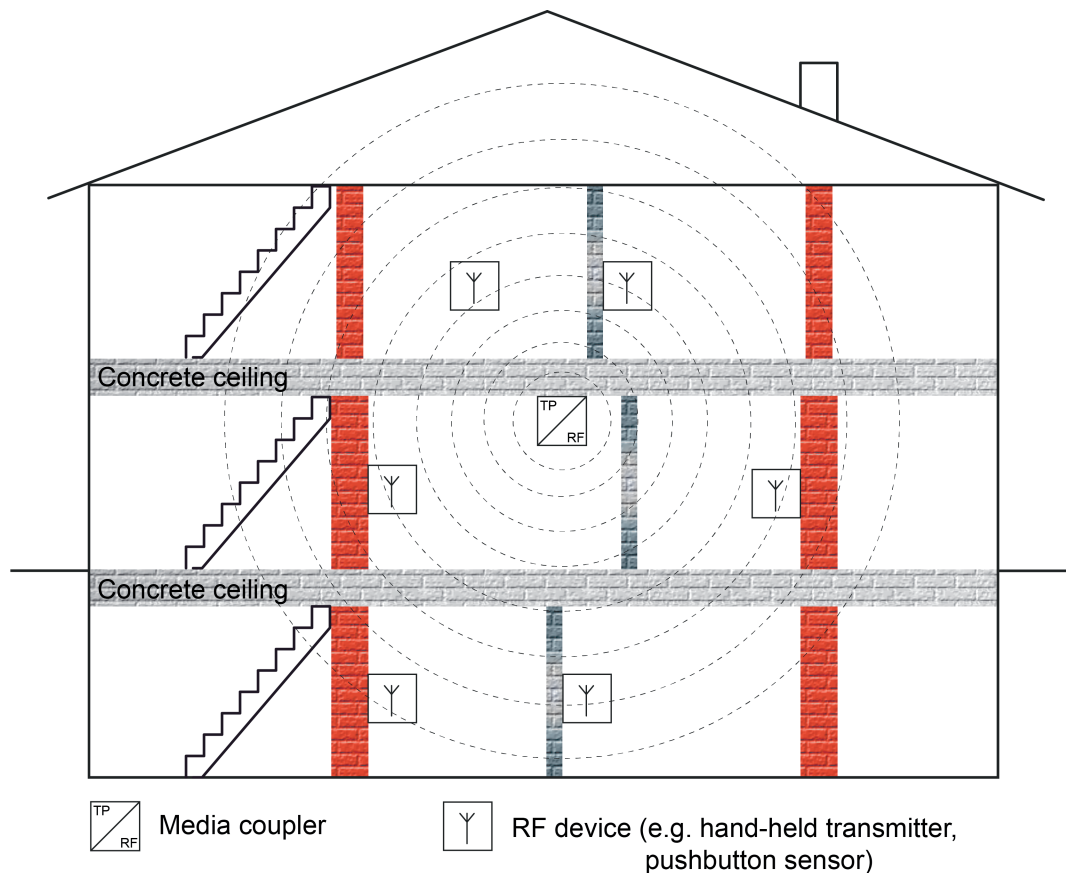

Figure 12: Building with a KNX RF line (example)

The frequency band at 868 MHz as used by the KNX RF has good signal radiation in buildings, since the attenuation due to walls, concrete reinforcements and metal parts close to the transmitter keeps within reasonable limits. This is positive when - for example in a detached house - one storey or even multiple storeys are to be covered with one and the same RF line. The media coupler should then be positioned as close to the centre of the building as possible (Figure 12).

The good signal radiation may be a disadvantage in real estate if the RF lines influence each other physically, are only partially within their radio ranges due to a small spatial distance or through insufficiently large attenuation due to wooden ceilings or thin walls (Figure 13). Here, it is wise not to create two or more RF lines (each with their own media couplers), but to use RF repeaters which increase the radio range of one RF line (Figure 14). Here too, the media coupler should be positioned as close to the centre of the building as possible. Repeaters should ideally be located on the edges of the building although still within the range of the media coupler and also within the ranges of other repeaters.

i Gira media couplers can only work as media couplers, as media couplers and repeaters or only as repeaters. The operating mode is defined by the parameter setting and the physical address of the media coupler. The functional description of the media coupler describes this in more detail.

Combined operation of the media coupler and repeater function is helpful if, within a radio domain, all the RF subscribers are within radio range of the media coupler but are not however in the radio ranges of other RF subscribers. Here, the repeater integrated in the central media coupler ensures that telegrams from RF subscribers also actually reach all the other RF subscribers of the radio domain.

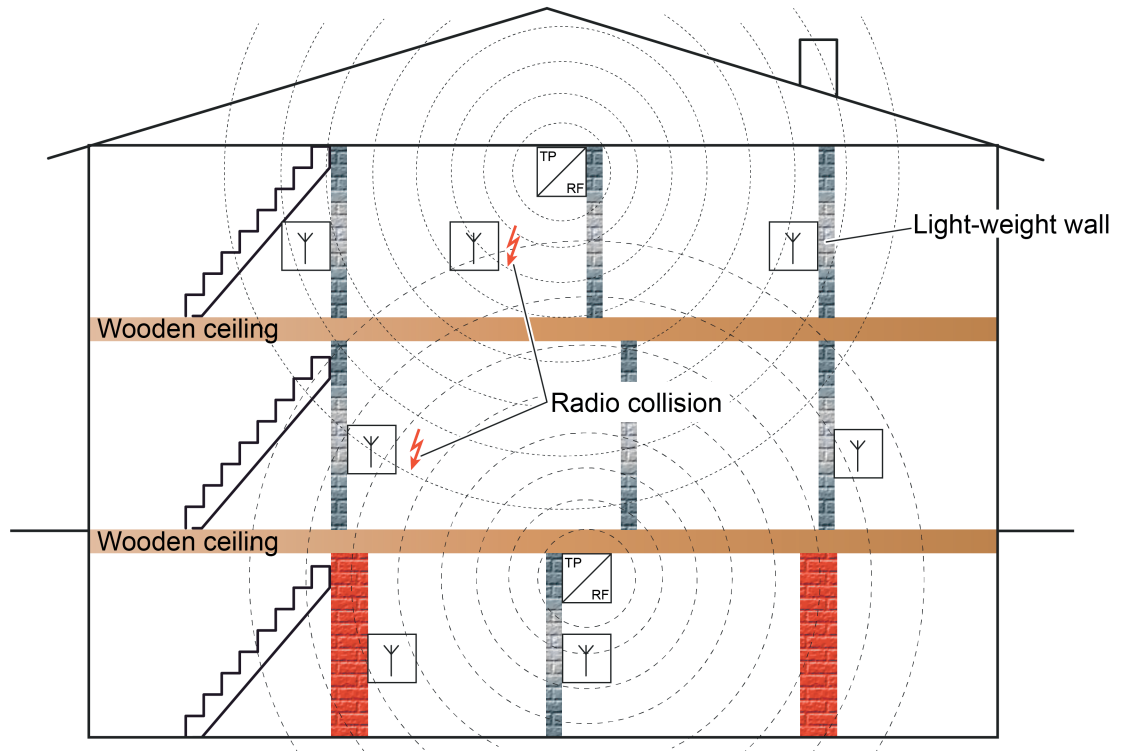

Figure 13: Building structure with two KNX RF lines, disadvantageous influence (example)

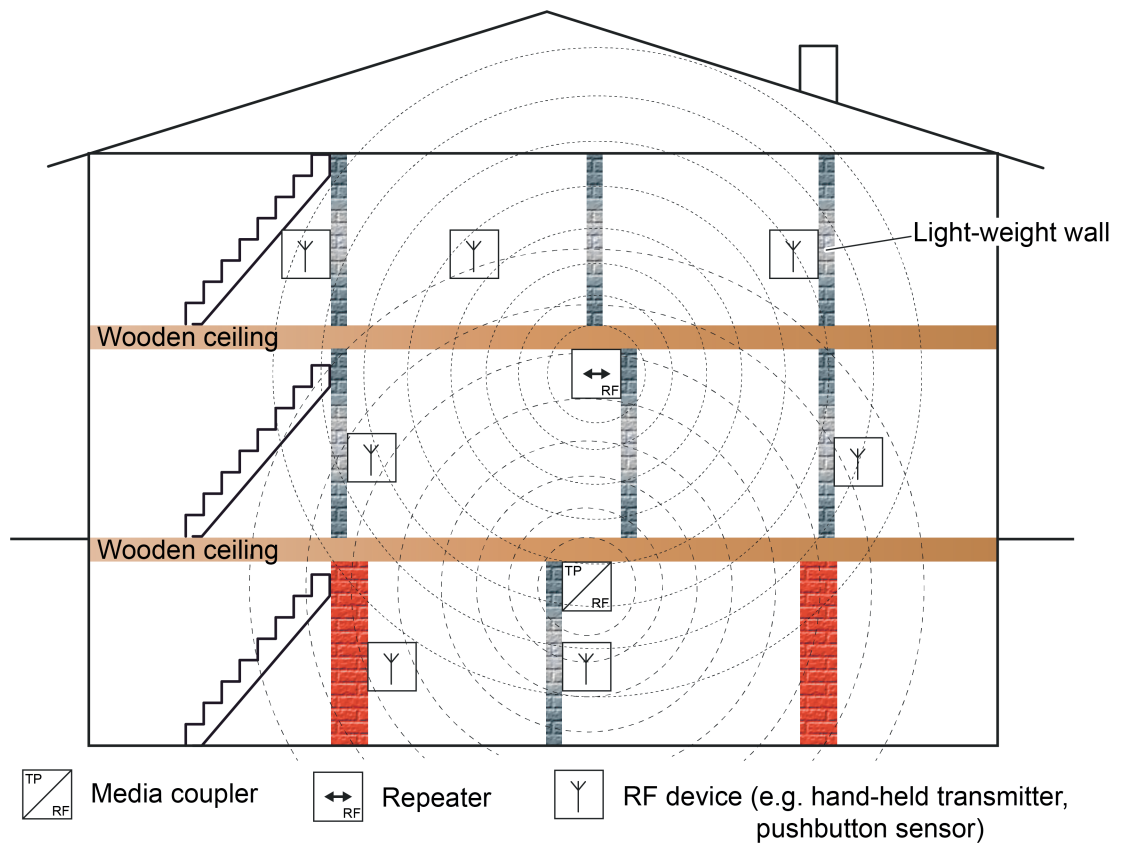

Figure 14: Building structure with one KNX RF line and repeater (example)

The use of more than one RF line is wise in large or extensive buildings or building sections, as the RF lines can then be separated sufficiently from one another, meaning that they no longer have a negative influence on one another. Different RF lines, each with their own media couplers, can also be used in smaller buildings (e.g. detached houses) or in apartment buildings, if the building structure and the consistency of the ceilings and walls shields the individual RF areas sufficiently (Figure 15). Underfloor heating can, for example, provide sufficient attenuation of the radio signals in the vertical direction. In the long-distance range, solid, supporting walls can make a positive contribution to achieving sufficiently large attenuation of the radio signals.

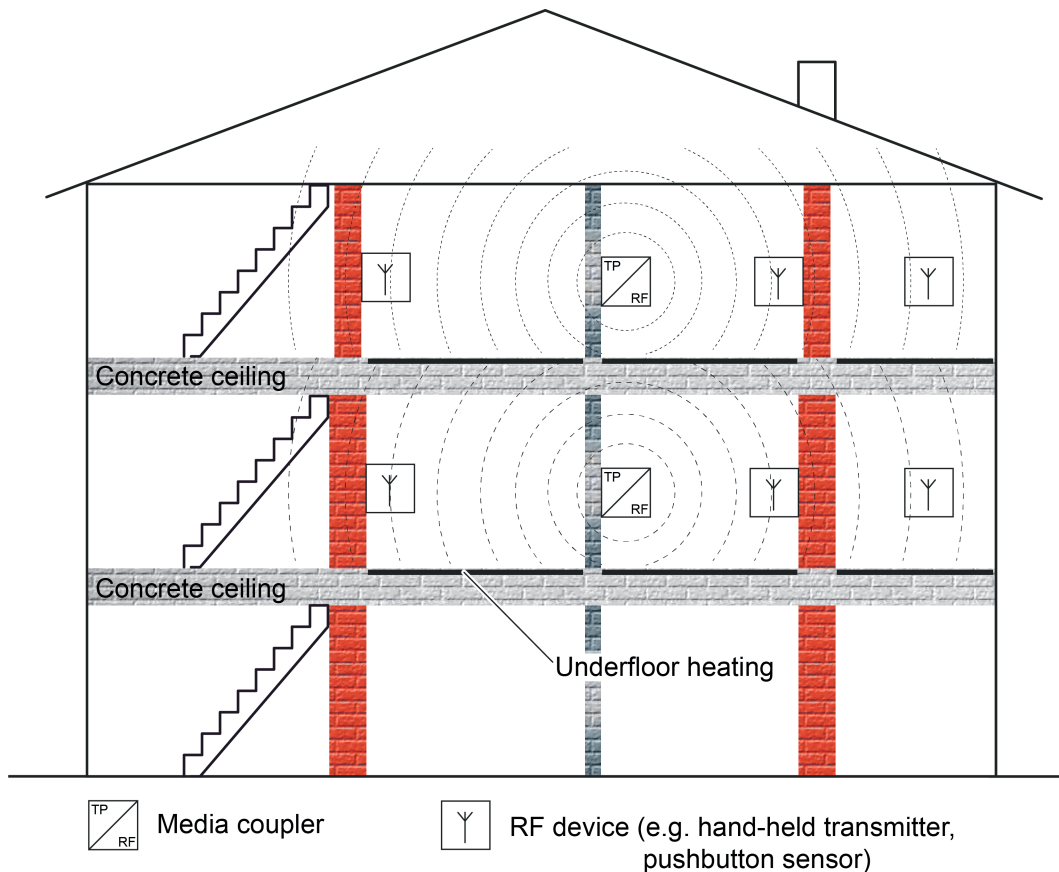

Figure 15: Building structure with two KNX RF lines, which do not influence each other negatively due to the building consistency (example)

A media coupler can also be used outdoors (if necessary as a repeater) in a suitable installation socket (ideally plastic AP WG), in order to make the KNX RF signals available directly between buildings or to amplify them. This means that KNX RF devices can be used outdoors - if the consistency of the buildings allows it - or in separate buildings (e.g. shed) (Figure 16).

Ideally, a repeater can also be used for signal amplification and the elimination of radio shadow through metallic furnishings or substances in the interior of the building.

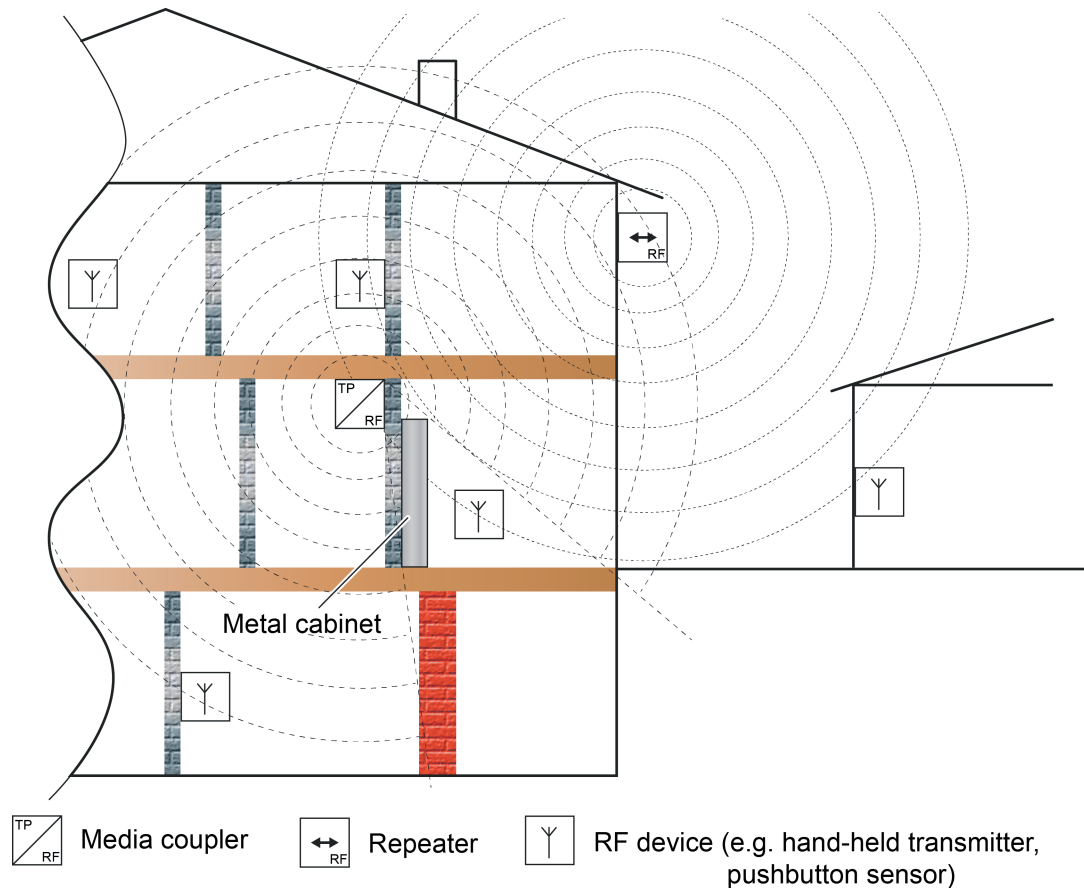

Figure 16: Use of a media coupler as a repeater for signal amplification and elimination of radio shadow for indoor and outdoor applications

Domain address for KNX RF

The radio range of KNX RF devices cannot be determined exactly in spatial terms. KNX RF telegrams cannot be limited to one specific KNX installation. Radio telegrams pass through the borders of buildings and plots of land and can be received by devices installed in neighbouring KNX systems. For this reason, it is important that different KNX RF installations are delimited topologically and thus logically from one another. The domain address helps here.

In accordance with the topology defined in the ETS project, devices assigned to the RF lines also always receive a domain address, in addition to the physical addresses. Only devices with the same domain address can communicate with each other within an RF environment. As a result, a media coupler must always have the same domain address as all the devices in its subordinate RF line.

- i** The domain address is defined in the ETS for each RF line or for each RF area. If an area is set to the media types "RF", then all the subordinate RF lines automatically receive the same domain address in the ETS.
The ETS programs the domain address automatically into the RF devices when the physical address is programmed.
- i** A domain address is 6 bytes long and is entered in the ETS in hexadecimals or generated automatically. After the first 2 bytes, the input notation requires a colon (when read from the left). For example, a domain address could look like this: "0011:22334455" or "00FA:4F5B3122".

- i** KNX RF systems always influence each other physically when they are spatially located in each other's radio range and two or more transmitters transmit more or less simultaneously, which is perfectly possible. Radio telegrams can be superimposed. In this case, the receivers can no longer evaluate the affected radio telegrams. For more information on the transmission property and superposition of RF telegrams, refer to the chapter "Basic physical principles" in this documentation (see page 16).

RF topology and ETS

Media couplers are the link between a specific KNX RF environment and a wired KNX TwistedPair installation. With regard to the routing property of telegrams, media couplers function like standard TP backbone/line couplers. This means that RF devices can communicate with TP or IP devices and vice-versa.

Media couplers possess filter settings and filter tables. The physical address defines whether a media coupler is a line coupler or a backbone coupler.

Optionally, the Gira media coupler can additionally or alternatively work as an RF repeater. A repeater repeats the radio telegrams received in its RF line by retransmitting them immediately. This allows an extension of the range of a KNX RF installation, meaning that it is possible to position RF devices as required in a building, even in the case of difficult transmission and reception conditions.

- i** The Gira media coupler is a device which allows the media type "RF" on the lower-level line and the media type "TP" on the higher-level line.

As with all other KNX components with S-Mode commissioning, KNX RF devices are configured and commissioned using the ETS. In consequence, RF devices also possess a physical address, parameters and communication objects. In addition, a unique domain address is assigned to each RF line in the ETS. Only devices with the same domain address can communicate with each other.

- i** Addressing, configuration and diagnostics of KNX RF devices are only implemented in the ETS of Version 5 or higher. Older versions of the ETS do not possess manufacturer-independent KNX RF support.

A media coupler can either be inserted in the KNX topology as a backbone coupler or, alternatively, as a line coupler. With KNX RF, there is generally no physical limitation of the number of possible bus subscribers as in a TP line (e.g. 64). With KNX RF, the number of subscribers is only limited by the physical addresses assigned in the ETS.

- Media coupler as line coupler:

A KNX RF line can contain up to 256 devices (including media coupler) (Figure 17). The media coupler is connected to the main TP line of an area. Additional TP lines can be set up using additional TP line couplers.

- i** There may only ever be one media coupler in an RF line.

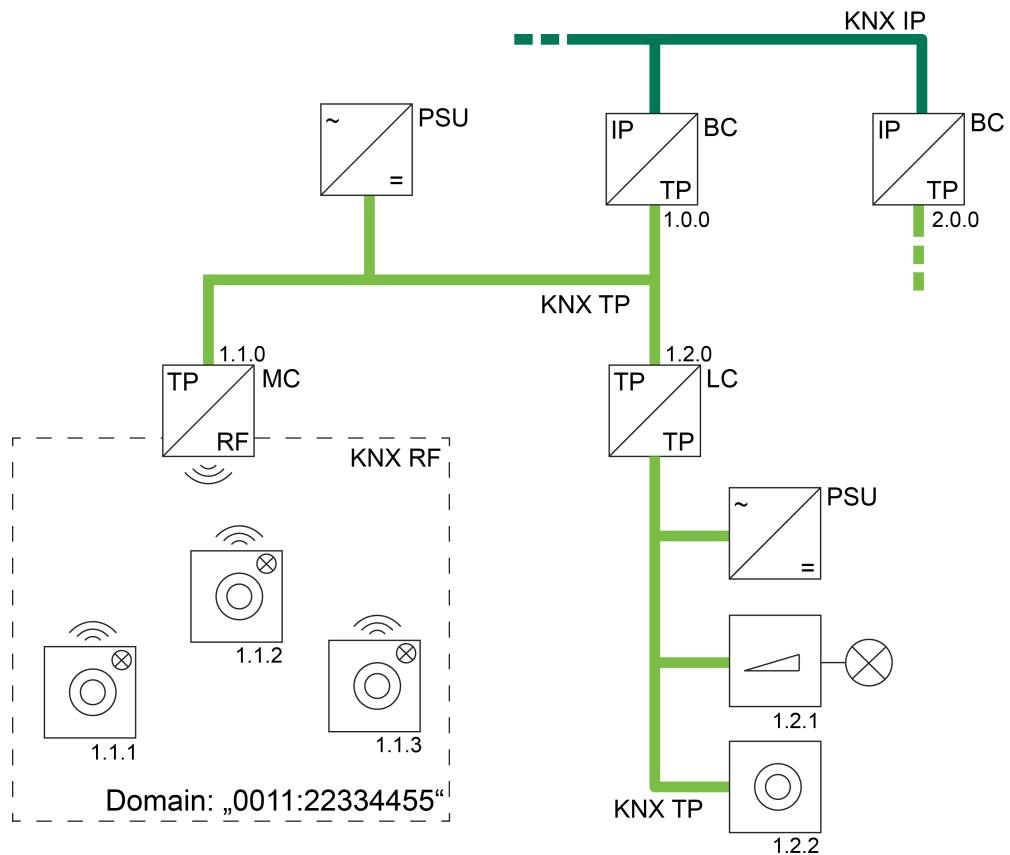

Figure 17: Example of a possible KNX topology with RF, TP and IP lines
Media coupler as line coupler

- MC Media coupler as line coupler (TP, RF)
- LC Line coupler (TP)
- BC Backbone coupler (as IP router / TP, IP)
- PSU Power supply (TP)

- Media coupler as backbone coupler:
If a media coupler is used as a backbone coupler, then a total of up to 4,081 RF devices (including media couplers) can be integrated into the appropriate area. The RF devices must then divide themselves up on the backbone line and on up to 15 additional subordinate RF lines (Figure 18). In the ETS, a maximum of 255 subscribers may exist for each area or line.
If the media coupler is a backbone coupler, then the backbone must possess the media type "TP". A KNX IP environment cannot then be implemented (the ETS prevents such a topology)!
- i** Even in an RF area, there may only be one media coupler (subordinate RF lines do not possess their own media coupler).
- i** Subordinate RF lines of an RF area always have the same domain address as the area itself.

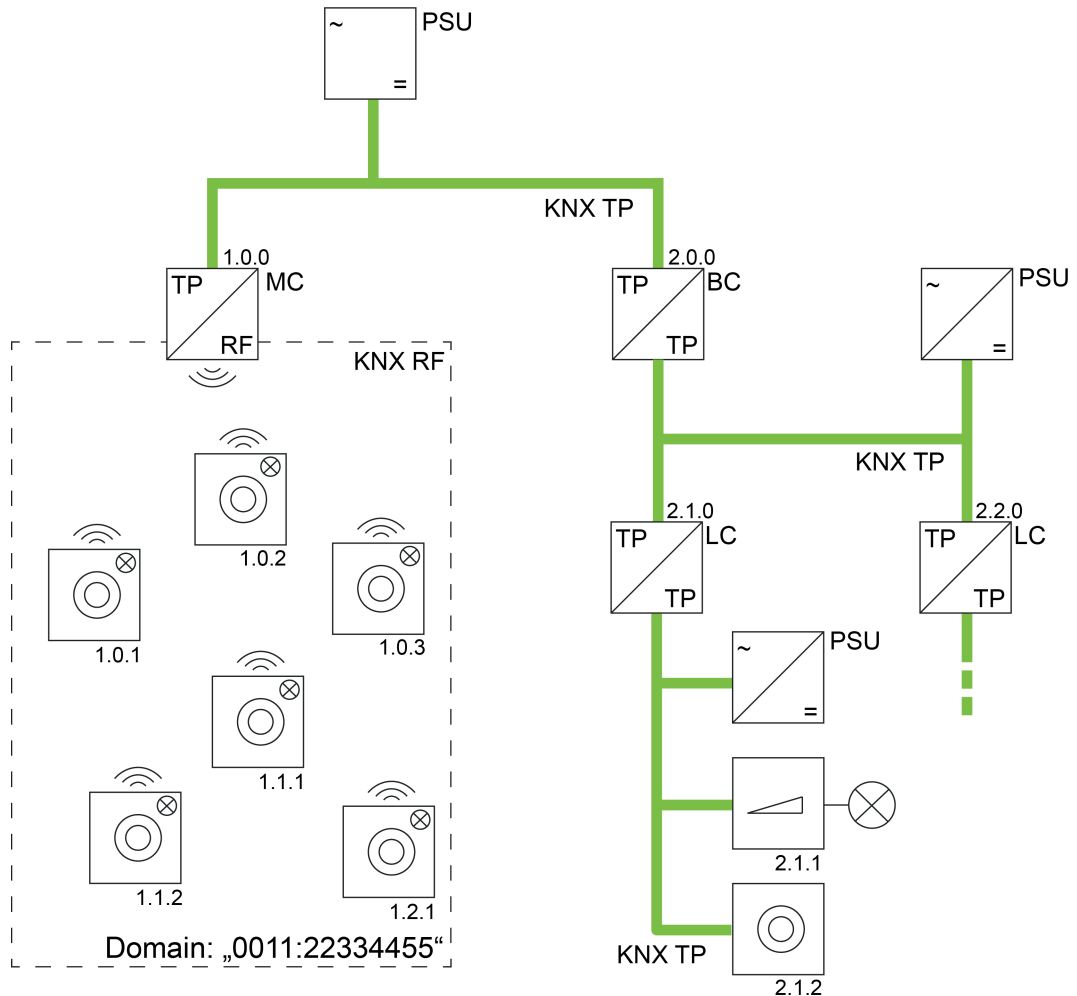

Figure 18: Example of a possible KNX topology with RF and TP lines
Media coupler as backbone coupler

- MC Media coupler as backbone coupler (TP, RF)
- LC Line coupler (TP)
- BC Backbone coupler (TP)
- PSU Power supply (TP)

Devices in different RF domains must be topologically divided into two different lines or backbones, each with their own domain addresses. These different areas or lines must also contain their own media couplers for the devices to be able to communicate with one another, irrespective of the line. The logical connection between two or more KNX RF environments is thus always made via media couplers and higher-level TP/IP lines (Figure 19).

KNX RF USB data interfaces, as used in the ETS, are also assigned to a domain address. In consequence, only RF devices of the same domain can be commissioned directly by radio telegram. Only group telegrams and physically addressed telegrams of the appropriate RF domain are recorded in the group monitor of the ETS (exception: System broadcast telegrams, see "Expert knowledge" further down). If other RF devices of another domain are to be contacted with an RF data interface, then communication via media couplers is necessary. If the KNX topology is set up correctly, then such communication takes place automatically via the KNX routing (precondition: media and backbone/line couplers forward the telegrams according to their filter property).

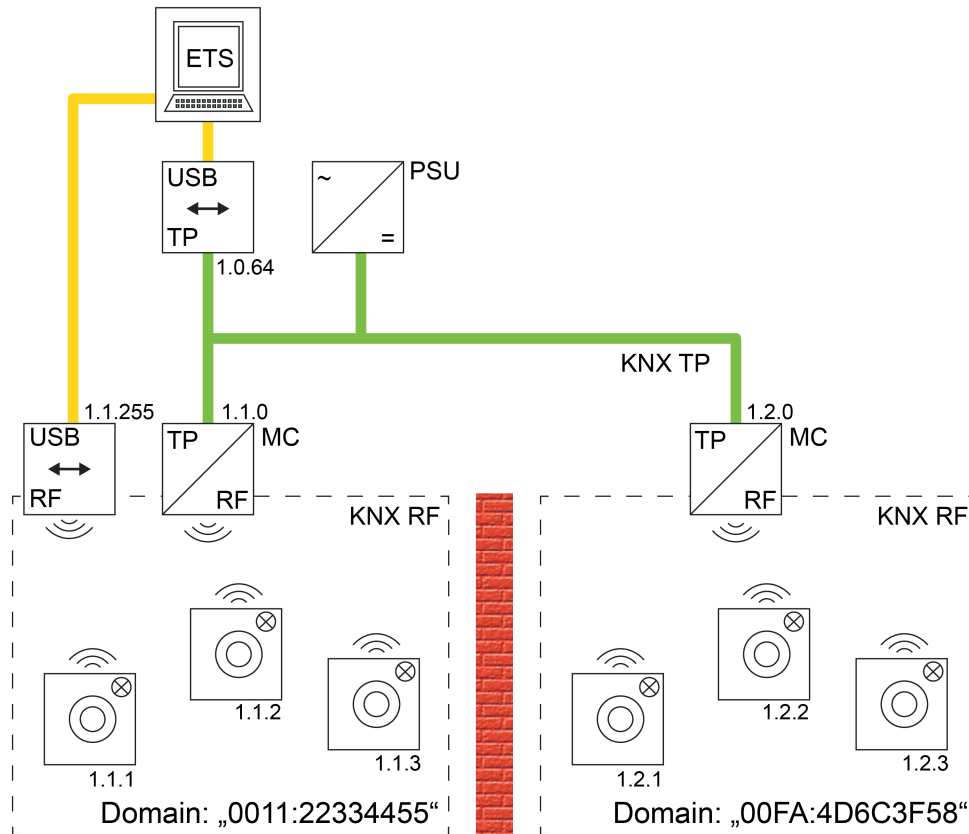

Figure 19: Example of a possible KNX topology with two RF lines and coupling via a TP main line (example)

- i** In general, multiple media couplers can be used in various lines and areas of a KNX topology. The ETS permits such a configuration. However, media couplers in a shared KNX system can influence each other unfavourably. In particular, during the commissioning of various bus devices using the ETS, radio telegrams may be superimposed, meaning that radio communication is poor or even impossible. Suitable precautions can be taken to avoid such a situation (spatial separation of the RF environments, logical filtering of specific telegrams).
- i** Media couplers cannot be used to network two or more KNX installations via RF (no proxy function)!
- i** RF areas or lines of a joint KNX installation or of directly adjacent KNX installations in radio range may never have an identical domain address! The ETS offers a function for random assignment of a domain address for RF lines, in order to avoid this improper situation. When the random function is used, the probability of multiple assignment of an identical address is more or less non-existent. A domain address automatically generated by the ETS is characterised by the hexadecimal characters "00FA..." (e.g. "00FA:4D6C3F58").

KNX RF systems are addressed, configured and diagnosed in the normal fashion via the ETS data interfaces.

- Use of a KNX RF USB data interface (Figure 20):
All the devices of an RF line or an RF area can be programmed and diagnosed directly via the KNX RF USB data interface. It is important that the KNX RF data interface has a valid physical address of the RF line or the RF area and is configured with the same domain address.
In addition, all the other devices of the KNX installation can be programmed using a media coupler with an identical domain address. A wired data interface is not essential for this.
If necessary, the KNX RF USB data interface can also be used in the group or bus monitor of the ETS5, in order to record RF telegrams of the corresponding RF domain.
- i** In the group monitor, a KNX RF USB data interface only displays group-addressed telegrams of the same RF domain. In addition, the interface displays physically addressed telegrams, provided that it is also used as the ETS programming interface. In the bus monitor, a KNX RF USB data interface only displays group-addressed telegrams.

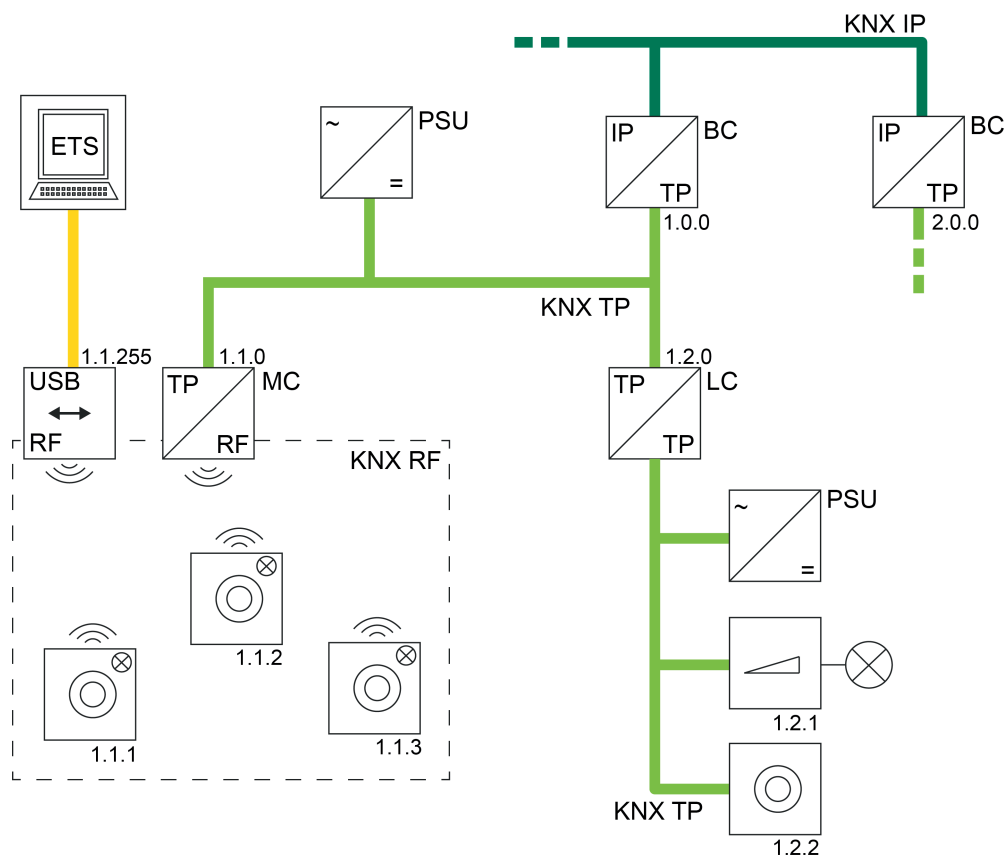

Figure 20: Example of a possible KNX topology with a KNX RF USB data interface

- Use of a KNX TP USB data interface (Figure 21):
RF devices can only be commissioned and diagnosed using a KNX TP USB data interface when a media coupler is also available. It is irrelevant in which line the KNX TP USB data interface is located so long as the topology of the KNX system is structured according to regulations (all the couplers and the data interface itself must have correct physical addresses and also guarantee telegram forwarding).

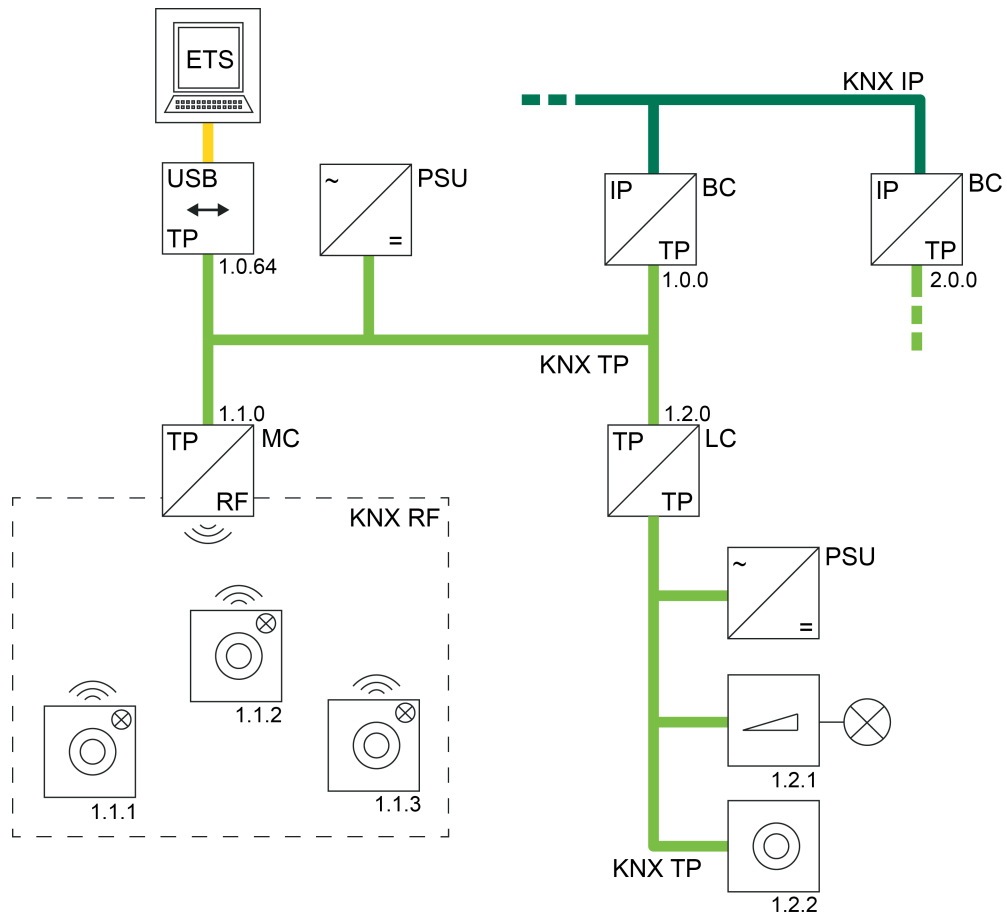

Figure 21: Example of a possible KNX topology with a KNX TP USB data interface

- Use of a KNX IP data interface (KNX/net IP) (Figure 22):
An IP connection of the ETS can also be used to commission or diagnose devices in a KNX RF environment. Here too, it is essential that a media coupler is available, which first connects the appropriate RF line in the correct manner with a TP line (main line of a TP area) and then with the IP environment (IP backbone) via a suitable IP router or an IP interface.
If the media coupler is a backbone coupler, then the backbone must possess the media type "TP". A KNX IP environment cannot then be implemented (the ETS prevents such a topology)!

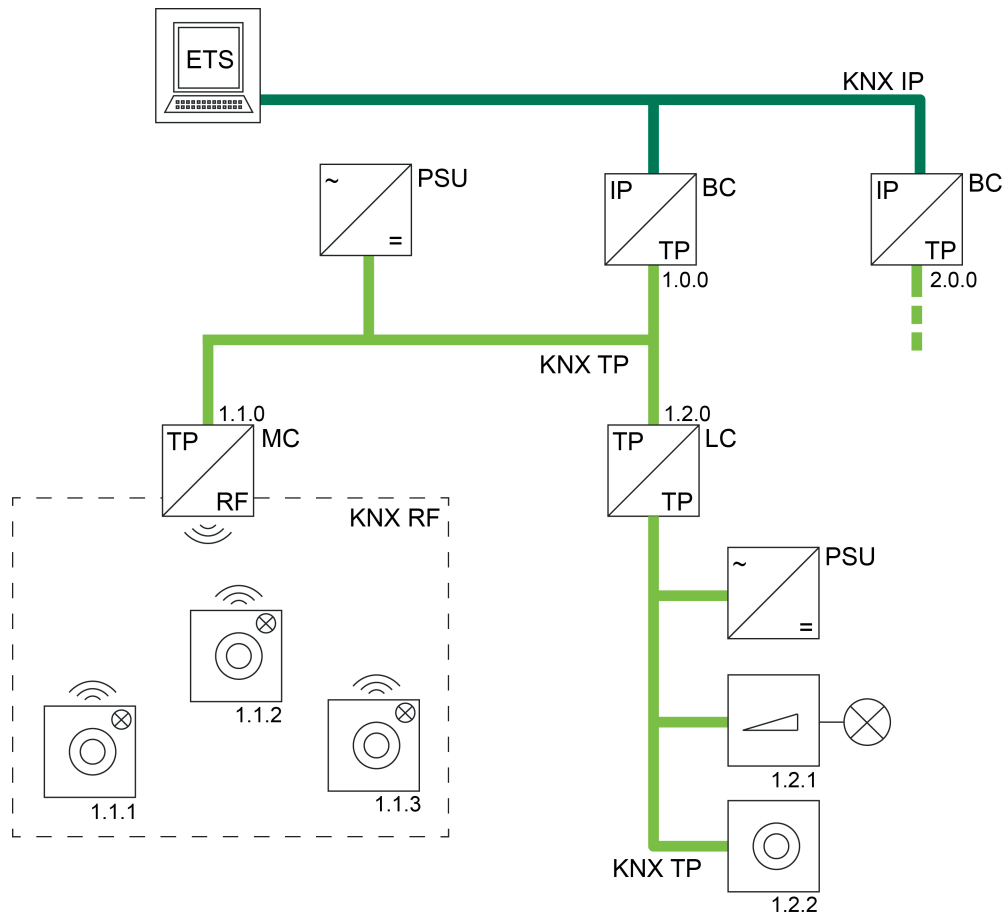

Figure 22: Example of a possible KNX topology with one KNX IP connection of the ETS (KNX/net IP)

RF addressing types (expert knowledge)

As with all KNX media, the payload data is also transmitted on the KNX RF using group telegrams (Multicast). A group telegram (e.g. to switch on the light) can be received from multiple bus subscribers simultaneously, provided that the communication objects of the devices are linked with identical group addresses. Besides the actual group address (2 bytes-long), the domain address (6 bytes-long) is also transmitted in an RF group telegram in accordance with "KNX RF 1.R S-Mode". This means that the recipients of the group telegrams can immediately detect whether they are addressed by the group address, are located in the same RF domain and thus whether they have to react to the group telegram. A media coupler inserts the required domain address into the group telegrams automatically, provided that they were received on the TP side and were transmitted to the RF environment in accordance with the filter setting. In the same way, a media coupler removes the domain supplement when a group telegram is received on the RF side and transmitted to the TP side.

A special type of group telegrams are broadcast telegrams (address 0/0/0). Broadcast telegrams always address all the bus subscribers in an RF environment or in the entire KNX system simultaneously. Such telegrams are used, for example, by the ETS, in order to program physical addresses or domain addresses or to read out which bus devices are in programming mode. Only in RF environments is a distinction made between simple broadcast telegrams and system broadcast telegrams. Only the latter are domain-independent and generated by media couplers as required, if the ETS, for example, has to program or diagnose RF devices via media couplers (TP -> RF). The ETS controls the available media couplers as necessary, so that the conversion of TP broadcast to RF system broadcast telegrams takes place in a targeted manner

and these system telegrams are forwarded.

In the same way, a media coupler converts system broadcast telegrams to normal broadcast telegrams on the TP side. Here too, the ETS automatically controls the function of the routing of such system telegrams in media couplers as required.

The ETS can generate direct system broadcast telegrams when it communicates via an RF USB data interface.

Besides broadcast telegrams, the ETS also uses physically-addressed telegrams in the RF system to program RF devices (Unicast).

- i Group telegrams, broadcast telegrams and physically addressed telegrams can be filtered independently of each other in the media coupler as required or can even be disabled completely. This allows RF lines to be decoupled logically from the rest of the KNX system, according to requirements.

6 Index

A

application program..... 11

B

Building structure..... 24

C

Commissioning..... 6,11

communication fault..... 23

D

Device components..... 5

Domain address..... 7,27

E

Electromagnetic wave..... 16

ETS project design..... 11

ETS search paths..... 9

F

frequency use..... 12

H

HID Driver..... 6

I

Information transmission..... 16

Initialisation..... 6

installation location..... 22

interference..... 21

M

modulation type..... 16

multiple route radiation..... 20-21

P

physical address..... 6

Protection cap..... 5

R

Recording type..... 5

reflection..... 21

RF addressing types..... 34

RF topology..... 28

U

USB Driver..... 6

Gira
Giersiepen GmbH & Co. KG
Elektro-Installations-
Systeme

Industriegebiet Mermbach
Dahlienstraße
42477 Radevormwald

Postfach 12 20
42461 Radevormwald

Deutschland

Tel +49(0)21 95 - 602-0
Fax +49(0)21 95 - 602-191

www.gira.de
info@gira.de